

Attachment A

**Planning Proposal – 47-51 Riley Street,
Woolloomooloo**

Planning Proposal: 47 – 51 Riley Street, Woolloomooloo



Contents

Executive summary	4
1. Site Identification	6
2. Existing planning controls	12
3. Objectives and intended outcomes	16
4. Explanation of provisions	17
5. Justification	18
6. Mapping	38
7. Community consultation	39
8. Project timeline	40
Appendix 1	41

Table of figures

Figure 1. Land affected by this Planning Proposal	6
Figure 2. Aerial photo of the site	7
Figure 3. 47 – 51 Riley Street, viewed from the east, outlined in red (Riley Street frontage)	8
Figure 4. 47 – 51 Riley Street (outlined in red) and adjoining properties, viewed from the south-east (Riley Street frontage)	9
Figure 5. 47 – 51 Riley Street (outlined in red) and adjoining properties, viewed from the north-east (Riley Street frontage)	9
Figure 6. Properties opposite 47 – 51 Riley Street, on eastern side of Riley Street	10
Figure 7. 47 – 51 Riley Street, viewed from the north-west, outlined in red (Busby Lane frontage)	10
Figure 8. 47 – 51 Riley Street, viewed from the south-west, outlined in red (Busby Lane frontage)	11

Planning Proposal:
47 – 51 Riley Street, Woolloomooloo

Figure 9. Development to the rear of 47-51 Riley Street, on opposite side of Busby Lane	11
Figure 10. Extract from zoning map in Sydney LEP 2012	12
Figure 11. Extract from Height of building map in Sydney LEP 2012	13
Figure 12. Extract from floor space ratio map in Sydney LEP 2012	14
Figure 13. Extract from heritage map in Sydney LEP 2012	15
Figure 14. Extract from planning proposal map showing proposed changes to boundaries of Woolloomooloo Heritage Conservation Area (C71)	15
Figure 15. Artistic representation of indicative design – Riley Street perspective, eastern elevation	18
Figure 16. Artistic representation of indicative design – Riley Street perspective	19
Figure 17. Artistic representation of indicative design – Riley Street perspective	19
Figure 18. Artistic representation of indicative design – Busby Lane perspective, western elevation	20
Figure 19. Proposed maximum building envelope – 3D view from the north east	29
Figure 20. Proposed maximum building envelope – 3D view from the south west	29
Figure 21. Proposed maximum building envelope – Riley Street elevation	30
Figure 22. Proposed maximum building envelope – looking north	30
Figure 23. Existing and proposed shadow impacts on residential façade of 60-70 William Street to the south	31
Figure 24. Key local views from nearby buildings	32
Figure 25. Ground floor plan of indicative design showing retail use and commercial lobby fronting Riley Street	33
Figure 26. Indicative design of basement carpark	34

Executive summary

The City of Sydney (the City) has prepared this planning proposal for 47 – 51 Riley Street, Woolloomooloo (the site) in response to a request from the landowner and proponent, RileyCorp Pty Ltd.

The planning proposal will enable development on the site consistent with the objectives and priorities of the Greater Sydney Region Plan, the Eastern City District Plan and the City's Local Strategic Planning Statement. This proposal seeks to increase the maximum building height and floor space ratio to support the site's future redevelopment and to achieve the following key benefits:

- the delivery of approximately 2150 square metres of new commercial workspace in Woolloomooloo, helping to promote investment, business and employment opportunities in a well-positioned location supported by existing social and transport infrastructure;
- a built form that respects the low and mid rise scale of adjoining properties through the use of a podium and a three storey street wall height, and uses setbacks for upper levels to reduce impacts on the streetscape and provide a transition to the nearby high rise buildings;
- permitting greater development and density while preserving amenity of nearby residential apartments, including in relation to solar access; and
- a retail tenancy at ground floor level to encourage a diverse and active street frontage and contribute to the character, amenity and vibrancy of Riley Street.

The site

The site has an area of 580 square metres. It is located to the east of the Sydney CBD, on the western edge of Woolloomooloo. The site's primary frontage is to Riley Street, and there is a secondary frontage to Busby Lane. The site is occupied by a part two / part three storey building which dates from the 1960s and is comprised of approximately 1000 square metres of office floor space. There is a basement carpark with 14 onsite parking spaces. Vehicular and servicing access is from Busby Lane. The site is located within a block of five properties which have a mixture of architectural styles. Immediately adjoining the site to the south is a two storey Victorian terrace style shop top building with a food and drink premises on the ground floor level. To the immediate north of the site is a part four / part five storey building with a food and drink premises at ground floor level and residential apartments above.

Existing development controls

Under the existing Sydney Local Environmental Plan 2012 (Sydney LEP 2012) controls, the site is zoned MU1 Mixed Use permitting a broad range of uses including office, retail and residential. The site has a maximum floor space ratio of 2:1 and a maximum building height of 12m.

The planning proposal – Sydney Local Environmental Plan 2012 controls

The City has prepared this planning proposal following a detailed review of the proponent's planning proposal request and accompanying documentation.

This planning proposal seeks to insert a new site-specific clause in Part 6, Division 5 of the Sydney LEP 2012 to:

- increase the maximum building height from 12 metres to 25 metres; and
- increase the maximum floor space ratio from 2:1 to 3.8:1 (exclusive of end of journey floor space at basement level).

As the planning proposal is aimed at supporting the commercial development of the site, the proposed increase to the maximum building height and FSR for the site will be available to commercial uses.

Draft site-specific amendment to Sydney Development Control Plan 2012

The City has prepared a draft site-specific amendment to the Sydney Development Control Plan 2012 (Sydney DCP 2012) to help ensure the objectives and intended outcomes of this planning proposal are achieved. The draft amendment to the Sydney DCP 2012 includes controls relating to the built form of the proposed development, site access and servicing, street activation and urban ecology.

The City intends to publicly exhibit the draft DCP amendments alongside this planning proposal.

1. Site Identification

1.1. Site Identification

The address and lot reference affected by this planning proposal are collectively referred to as 'the site'. The site is located at 47 – 51 Riley Street, Woolloomooloo and the lot reference is Lot 1 in DP 83489. A map of the site, outlined in red, is shown at Figure 1.

Figure 1. Land affected by this Planning Proposal



1.2. Site location

The site is located in Woolloomooloo within the City of Sydney Local Government Area. It fronts Riley Street to the east and Busby Lane to the west.

The site is located to the east of the Sydney CBD, around 800 metres from Town Hall Railway Station with intercity, suburban, light rail and bus connections. St James' Railway station is around 600 metres away and Museum Station around 900 metres away – both of these stations provide access to intercity trains and suburban trains. To the south of the site is William Street, which is a key connector between the City and the Eastern Suburbs. The site is close to bus stops on Riley Street and William Street, which provide access to various destinations across metropolitan Sydney. The site is located in close proximity to Cook and Phillip Park, Hyde Park and the Domain.

An aerial photo of the site and surrounding area is shown at Figure 2.

Figure 2. Aerial photo of the site

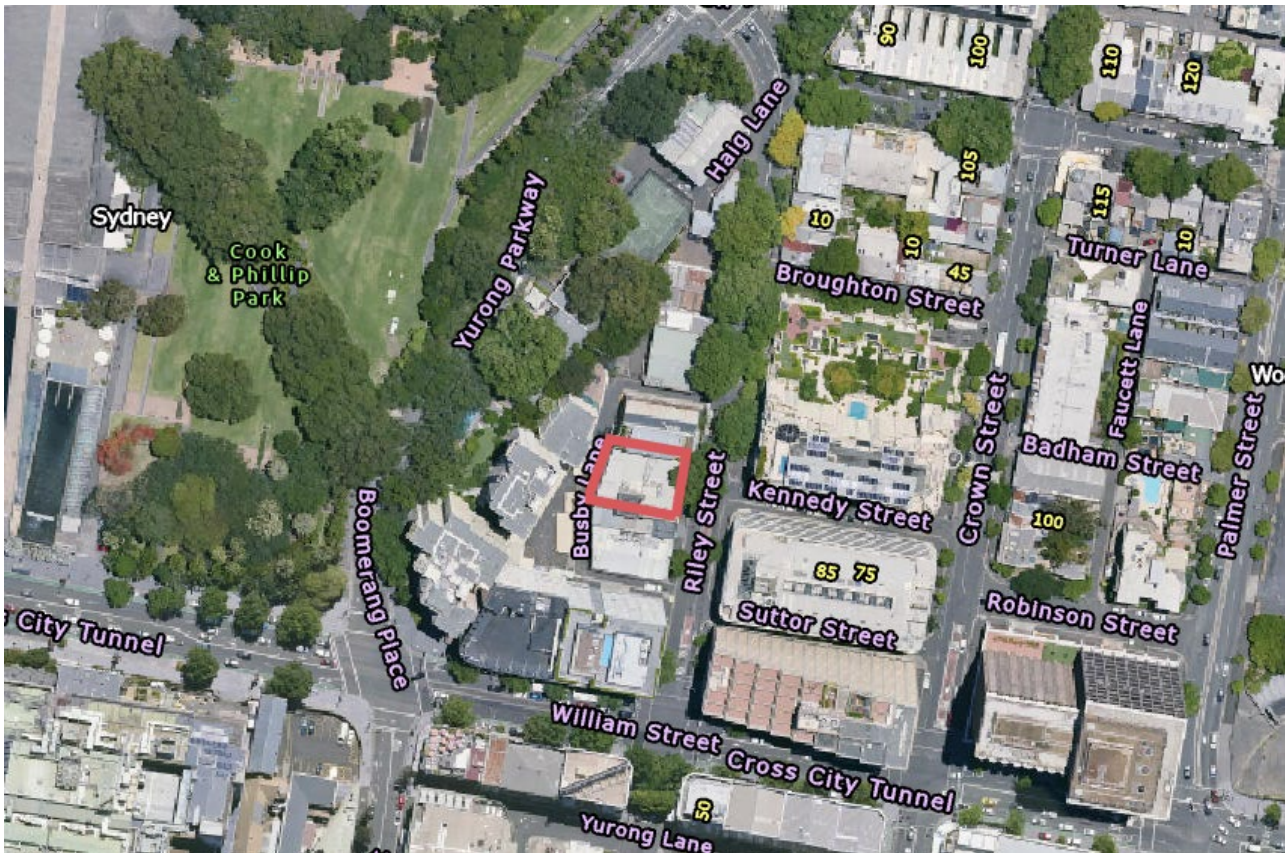

1.3. Site characteristics

The site has an area of 580 square metres. The Riley Street frontage is approximately 21 metres. The Busby Street frontage is angled, with a section approximately 2 metres in length and another section of 19 metres. The site slopes gently downwards from south to north.

The site is occupied by a part two/part three storey commercial building with 1000 square metres of office floor space. Pedestrian access to the offices is via Riley Street. There is a basement carpark with 14 car parking spaces accessed from Busby Lane.

The site is located within a street block comprised of five properties, each occupied with buildings of differing architectural styles. To the immediate south of the site at 53 Riley Street is a two storey Victoria style shop top housing development. Further south at 55-61 Riley Street is a two storey building with a decorative front facade which is currently empty but was previously occupied by a restaurant. To the immediate north of the site, at 43-45 Riley Street, is a part four/part five storey building with a food and drink premises at ground floor level and residential apartments above. Further north at 41 Riley Street is a three storey building with a decorative roof form that is occupied by commercial offices.

Beyond the street block, to the south and south-west, there are high rise developments. At 60-70 William Street, there is a mixed use building with retail and commercial uses on the ground floor and residential apartments on the floors above. At 52-58 William Street, there is a commercial building, part of which was granted development consent (D/2022/1354) in December 2023 to be converted into an educational establishment. This consent includes approval for the construction of

an outdoor play area above the carpark at the rear of the site which is accessed and has frontage along Busby Lane.

To the west of the site, there are two high rise residential buildings known as Park Lane Towers, with a street address of 1 Boomerang Place.

To the north of the site, on the opposite side of Busby Place, there are low rise commercial office premises and an automotive garage.

Opposite the site, on the eastern side of Riley Street, are high rise developments. To the north east are residential apartments at 63 Crown Street. To the south east is a commercial building which contains a supermarket with its main entry on Crown Street, and a commercial building with its main frontage on William Street.

Figure 3. 47 – 51 Riley Street, viewed from the east, outlined in red (Riley Street frontage)

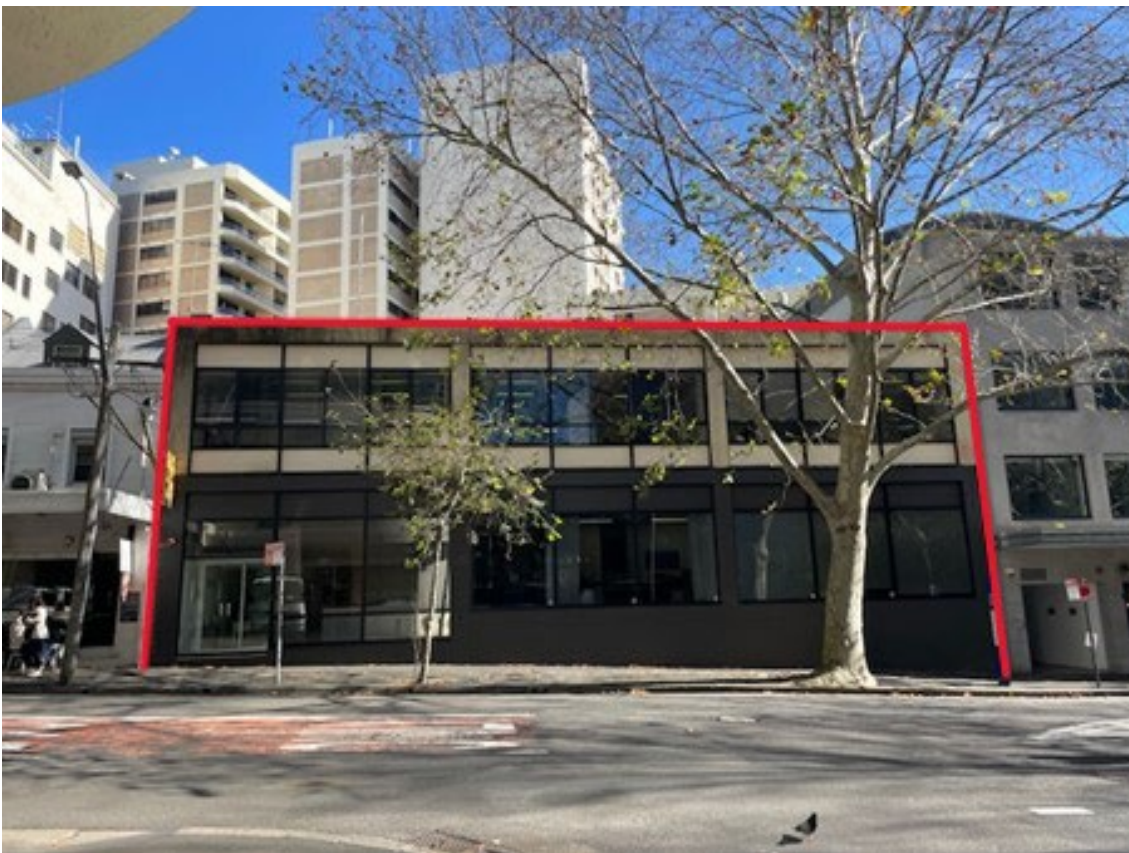

Figure 4. 47 – 51 Riley Street (outlined in red) and adjoining properties, viewed from the south-east (Riley Street frontage)



Figure 5. 47 – 51 Riley Street (outlined in red) and adjoining properties, viewed from the north-east (Riley Street frontage)



Figure 6. Properties opposite 47 – 51 Riley Street, on eastern side of Riley Street



Figure 7. 47 – 51 Riley Street, viewed from the north-west, outlined in red (Busby Lane frontage)



Figure 8. 47 – 51 Riley Street, viewed from the south-west, outlined in red (Busby Lane frontage)



Figure 9. Development to the rear of 47-51 Riley Street, on opposite side of Busby Lane



2. Existing planning controls

2.1. Zoning

The site is located within the MU1 Mixed Use Zone. The objectives of this zone are to:

- encourage a diversity of business, retail, office and light industrial land uses that generate employment opportunities.
- ensure that new development provides diverse and active street frontages to attract pedestrian traffic and to contribute to vibrant, diverse and functional streets and public spaces.
- minimise conflict between land uses within this zone and land uses within adjoining zones.
- encourage business, retail, community and other non-residential land uses on the ground floor of buildings.
- ensure land uses support the viability of nearby centres.
- integrate suitable business, office, residential, retail and other land uses in accessible locations that maximise public transport patronage and encourage walking and cycling.

Figure 10. Extract from zoning map in Sydney LEP 2012

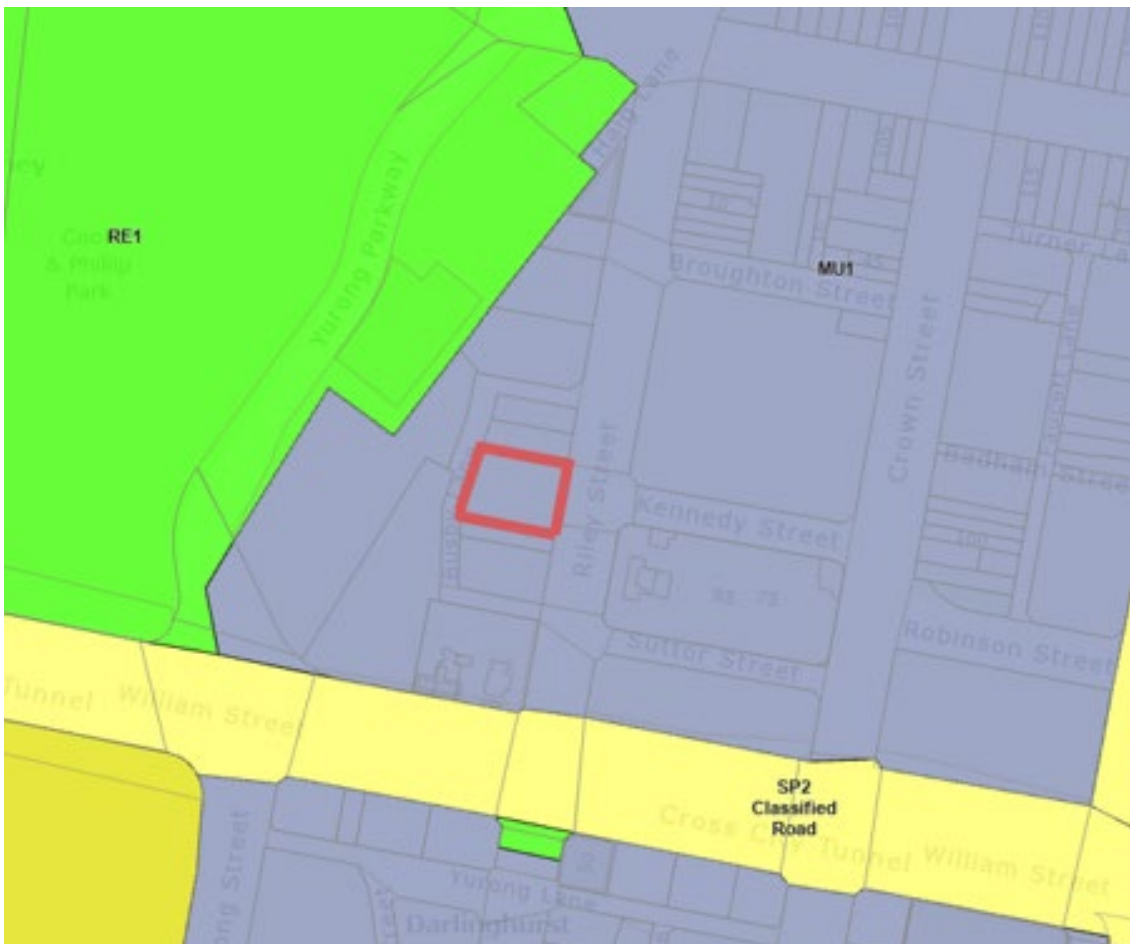

2.2. Building height

The maximum building height for the site is 12m, represented by 'M' and the yellow shading in Figure 11. It is not affected by any Sun Access Plane or No Additional Overshadowing controls.

Figure 11. Extract from Height of building map in Sydney LEP 2012



2.3. Floor space ratio

The maximum floor space ratio for the site is 2:1, as indicated by 'T1' and the pink shading in Figure 12.

Figure 12. Extract from floor space ratio map in Sydney LEP 2012



2.4 Heritage

The site is not heritage listed but is located within the Woolloomooloo Heritage Conservation Area (C71) under Sydney LEP 2012. However, the City is currently progressing a planning proposal which reviews the boundaries of the existing conservation areas. The site and those surrounding it are proposed to be removed from the Woolloomooloo Heritage Conservation Area.

The site is located in close proximity to a number of local heritage items. There are four locally listed commercial buildings near the site – the “Brandt Bros Ltd” building at 41 Riley Street (I2190), “Lesseys Garage” at 55-61 Riley Street (I2192), the “Former Hastings Deering Building” at 46-48 Riley Street (I2191) and the “Peejays Building” at 52-58 William Street (I2198). The nearby Cook and Phillip Park is also a locally listed heritage item (I1655).

A map showing the site’s location within the Woolloomooloo Heritage Conservation Area (C71) and the locally listed heritage items is at Figure 13. A map showing the proposed changes to boundaries of the Woolloomooloo Heritage Conservation Area (C71) is at Figure 14.

Figure 13. Extract from heritage map in Sydney LEP 2012

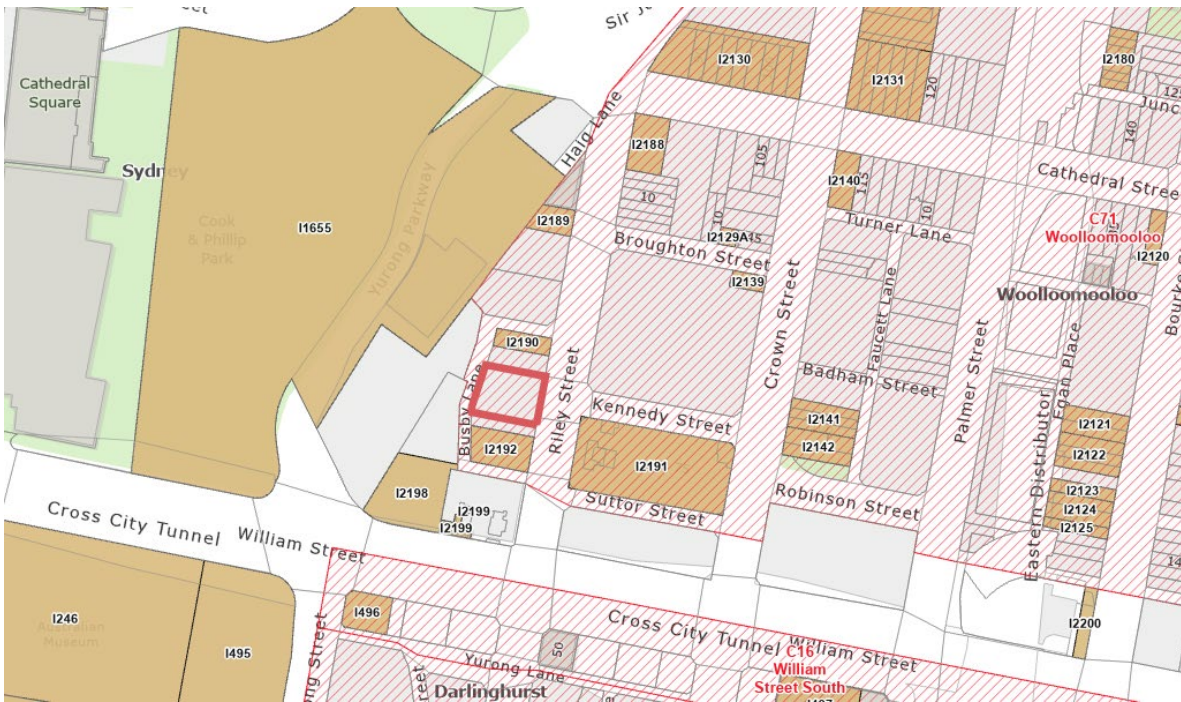

Figure 14. Extract from planning proposal map showing proposed changes to boundaries of Woolloomooloo Heritage Conservation Area (C71)



3. Objectives and intended outcomes

3.1. Objectives

This planning proposal will enable the redevelopment of 47 – 51 Riley Street, Woolloomooloo to deliver:

- a five storey building with approximately 2150 square metres of commercial floor space which is appropriate in the MU1 Mixed Use zone and will contribute to jobs growth in the City Fringe;
- a building which is responsive to the surrounding built form, streetscape and character of Riley Street and will enhance the amenity of the public domain;
- a building that contributes to the activation of Riley Street through the provision of retail floorspace at ground floor level;
- a building that will respond to the site's location in a flood planning area, with future detailed design to set floor levels above flood level;
- built form parameters which will minimise overshadowing and view impacts on nearby residential properties; and
- a building which contributes to the greening of the City with a green roof which will assist in mitigating the urban heat island effect.

4. Explanation of provisions

4.1. Sydney Local Environmental Plan 2012

To achieve the objectives and intended outcomes, this planning proposal seeks to amend Sydney Local Environmental Plan 2012 (Sydney LEP 2012) by inserting a new site-specific clause in Part 6, Division 5 Site Specific Provisions to:

- permit a maximum building height of 25 metres; and
- permit a maximum floor space ratio of 3.8:1.

As the planning proposal is aimed at supporting the requested commercial development of the site, the proposed increase to the maximum building height and FSR for the site will be available to support commercial uses.

Appendix 1 of this Planning Proposal provides some example clauses of the proposed controls. The final version of the clauses to be inserted into Sydney LEP 2012 will be subject to drafting and agreement by the Parliamentary Counsel's Office.

4.2. Sydney Development Control Plan 2012

To ensure future development is consistent with the objectives of the planning proposal, site specific provisions for the Sydney Development Control Plan 2012 (Sydney DCP 2012) will be drafted to ensure a high-quality built form that responds to the existing context and minimises impacts on nearby residential properties. These include provisions relating to building height in storeys, street wall heights, setbacks, vehicular and pedestrian site access, ground floor activation and inclusion of a green roof.

A draft of the new site specific provisions for the Sydney DCP 2012, also to be placed on public exhibition, can be found at Attachment B.

5. Justification

5.1 Landowner request

The landowner and proponent, RileyCorp Pty Ltd, lodged a formal request to prepare a planning proposal in April 2024. The intended use of the site is for a commercial development. Testing was done for commercial use. The indicative design submitted in support of the request depicts an office building of five storeys with a ground floor retail use, and rooftop services with a pergola structure and communal open space.

Figure 15. Artistic representation of indicative design – Riley Street perspective, eastern elevation



Figure 16. Artistic representation of indicative design – Riley Street perspective



Figure 17. Artistic representation of indicative design – Riley Street perspective



Figure 18. Artistic representation of indicative design – Busby Lane perspective, western elevation



5.2 Need for the planning proposal

Is the planning proposal a result of an endorsed LSPS, strategic study or report?

This planning proposal is the result of a request from the landowner to change the planning controls that relate to the site.

The landowner commissioned a Planning Proposal Justification Report prepared by FPD Planning, an Urban Design Report prepared by SJB and other studies in support of the request. Together these reports and studies describe how the proposal is consistent with the City's Local Strategic Planning Statement (City Plan 2036) and demonstrate how the site is capable of accommodating growth in employment generating floor space through amending building height and floor space ratio controls without resulting in unacceptable impacts on the public domain and amenity.

The supporting documents commissioned by the landowner to support the request are attached as the Attachments to this planning proposal:

- Attachment A1: Planning Proposal Justification Report – FPD Planning
- Attachment A2: Consideration of Sydney DCP – FDP Planning
- Attachment A3: Additional information to support Planning Proposal – FDP Planning
- Attachment A4: Urban Design Report – SJB
- Attachment A5: Site Survey – Denny Linker & Co
- Attachment A6: Aboriginal Heritage Due Diligence – Extent Heritage Pty Ltd
- Attachment A7: Baseline Archaeological Assessment – Extent Heritage Pty Ltd
- Attachment A8: Heritage Impact Statement – NBRS & Partners Pty Ltd
- Attachment A9: Flood Impact Assessment – Barker Ryan Stewart

- Attachment A10: Transport Assessment – Colston Budd Rogers & Kafes Pty Ltd
- Attachment A11: Swept Path Diagrams – Colston Budd Rogers & Kafes Pty Ltd

Is the planning proposal the best means of achieving the objectives or intended outcomes, or is there a better way?

This planning proposal seeks to insert new site specific provisions into the Sydney LEP 2012. The resultant conditions have been assessed to ensure any future built form is appropriate and does not result in unacceptable impacts on adjoining properties or the public domain. The amended controls would facilitate the delivery of additional employment generating floor space in the City Fringe area consistent with the objectives of the Local Strategic Planning Statement.

5.3 Relationship to the strategic planning framework

Will the planning proposal give effect to the objectives and actions of the applicable regional or district plan or strategy?

A Metropolis of Three Cities – The Greater Sydney Region Plan

The planning proposal gives effect to the following objectives of the Greater Sydney Region Plan:

- **Objective 14: Integrated land use and transport creates walkable and 30-minute cities** – The site is located within walking distance of the Sydney CBD. It is also well located in relation to public transport. It is around 800 metres from Town Hall Railway Station, 600m from St James' Railway Station and 900m from Museum Station. To the south of the site is William Street, which is a key connector between the City and the eastern suburbs. The site is close to bus stops on Riley Street and William Street. The site's location within a mixed use zone, and in close proximity to residential areas, promotes the vision of a 30 minute City.
- **Objective 18: Harbour CBD is stronger and more competitive** – The provision of additional commercial floor space with flexible floor plates will contribute to the continued growth and competitiveness of the Harbour CBD.
- **Objective 22: Investment and business activity in centres** – The site is located within the metropolitan centre of the Eastern Harbour City. The provision of additional commercial floor space on the site will encourage investment and business activity, further supporting the economic significance of the Harbour CBD.

Eastern City District Plan

The planning proposal gives effect to the following Planning Priorities of the Eastern City District Plan:

- **Planning Priority E1: Planning for a city supported by infrastructure** – This planning proposal will facilitate the delivery of additional commercial floorspace on a site well-positioned to take advantage of existing and planned infrastructure, encouraging the efficient use of land.
- **Planning Priority E6: Creating and renewing great places and local centres, and respecting the District's heritage** – This planning proposal would facilitate the redevelopment of the site in a way that is responsive to the surrounding built form and respects the streetscape and character of Riley Street. It would enable the renewal of the site, so that a new development can make a positive contribution to the public realm. While the site lies within the Woolloomooloo Heritage Conservation Area (C71), the City is currently progressing a planning proposal which would see the site and certain surrounding sites removed from this conservation area. The planning proposal would respect the heritage significance of nearby local heritage items.
- **Planning Priority E7: Creating a stronger and more competitive Harbour CBD** – The provision of additional commercial floor space on the site will contribute to a stronger and more competitive Harbour CBD.

- **Planning Priority E10: Delivering integrated land use and transport planning and a 30-minute city** – The redevelopment of the site to provide additional commercial work space would be consistent with this priority, given that the site is well-positioned to take advantage of the metropolitan transport network, including rail, light rail and Metro connections as well as nearby bus services and cycleways.
- **Planning Priority E11: Growing investment, business opportunities and jobs in strategic centres** – This site is located within the metropolitan centre of the Eastern City District (Harbour CBD). The redevelopment of the site to provide new commercial floor space would support employment growth, while being well-positioned to take advantage of existing services and transport connections.

Is the planning proposal consistent with a council LSPS that has been endorsed by the Planning Secretary or GCC, or another endorsed local strategy or strategic plan?

City Plan 2036 (local strategic planning statement)

The planning proposal gives effect to the following priorities of City Plan 2036:

- **Priority I1: Movement for walkable neighbourhoods and a connected city** – This planning proposal would facilitate a new commercial development in a well located area to enable integration with existing and future transport connections. The site's location close to residential dwellings will promote opportunities for walkable neighbourhoods.
- **Priority I2: Align development and growth with supporting infrastructure** – This planning proposal would facilitate the development of new commercial office space well-positioned to take advantage of existing infrastructure, including rail, light rail and Metro connections, as well as nearby bus services and cycleways.
- **Priority L2: Creating great places** – This planning proposal would deliver improved street life and ground floor activation through a retail use fronting Riley Street, enhancing the character and visual interest of this part of Woolloomooloo.
- **Priority P2: Developing innovative and diverse business clusters in City Fringe** – This planning proposal supports growth in the City Fringe by facilitating future development of additional commercial floor space that can be adapted to a variety of business uses.

Sustainable Sydney 2030-2050: Continuing the vision

- **Direction 5: A city for walking, cycling and public transport** – The site is within walking distance of the Sydney CBD and is well positioned to take advantage of existing transport infrastructure, including rail, light rail and Metro connections and bus routes and cycleways.
- **Direction 9: A transformed and innovative economy** – This planning proposal supports employment growth in the City Fringe, helping to maintain the city's position as a destination for business, investment and talent.

Is the planning proposal consistent with any other applicable State or regional studies or strategies?

Not applicable.

Is the planning proposal consistent with applicable SEPPs?

The following table (Table 1) outlines the consistency of this planning proposal with applicable State Environmental Planning Policies (SEPPs).

Table 1. Consistency with applicable SEPPs

SEPP	Comment
SEPP (Biodiversity and Conservation) 2021	<p>This planning proposal is consistent. The site is located within the Sydney Harbour Catchment area but not within the Foreshores and Waterways Area.</p> <p>The existing building has full site coverage, and the proposed building envelope will also occupy the full site area. Given this, any future development is unlikely to increase the amount of stormwater runoff from the site.</p> <p>A Flood Impact Assessment has been prepared (See Attachment A9) and models flooding conditions at the site. The site is located in the Woolloomooloo catchment. The assessment states that there is significant overland flow along Riley Street in both the 1% AEP and PMF events. Flood depths in the 1% AEP event are below 100mm and present a low hazard, while in the PMF event flood depths are up to 500mm above the 1% AEP event. It notes that flood behaviour in Busby Lane is largely controlled by a trapped low point at the northern end of the lane, which causes flood waters to pond until spilling back onto Riley Street downstream of the site. The resultant flood depths are up to 1.1m in the 1% AEP event and up to 1.9m in the PMF event.</p> <p>In the indicative scheme, all basement access points have been located above the PMF level, including lift shafts and fire stairwells as well as the internal driveway crest at the entry to the basement.</p> <p>The floor levels of the retail and front lobby areas have been raised by 50mm in response to concerns raised about flood levels on Riley Street, but the final levels are to be determined at development application stage. The applicant advises that any future change to the retail and front lobby floor levels would not impact on the overall building height.</p> <p>The Flood Impact Assessment makes recommendations to reduce the risks and impacts of flood behaviour. A more detailed Flood Impact and Risk Assessment (FIRA) and Flood Emergency Response Plan (FERP) would need to accompany a development application for the redevelopment of the site.</p>
SEPP (Exempt and Complying Development Codes) 2008	This planning proposal is consistent.
SEPP (Housing) 2021	This planning proposal is consistent.
SEPP (Industry and Employment) 2021	This planning proposal is consistent.
SEPP (Planning Systems) 2021	This planning proposal is consistent.

SEPP	Comment
SEPP (Precincts – Eastern Harbour City) 2021	This planning proposal is consistent.
SEPP (Resilience and Hazards) 2021	<p>This planning proposal is consistent.</p> <p>The existing building on the site dates from the mid-1960s. It was constructed as an office building and this use continues today.</p> <p>Historical records show the site was used as a coach building and motor car workshop in the early 1900s.</p> <p>The City has considered the potential for contamination reflecting the history of the site. Further investigation regarding potential contamination and remediation would be needed as part of any future development application process.</p> <p>The site is not located within the Coastal Environment Area nor the Coastal Use Area.</p>
SEPP (Resources and Energy) 2021	This planning proposal is consistent.
SEPP (Sustainable Buildings) 2022	This planning proposal is consistent.
SEPP (Transport and Infrastructure) 2021	<p>This planning proposal is consistent.</p> <p>The site is not located in or adjacent to rail corridors. It is also not located in or immediately adjacent to road corridors or reservations listed in Section 2.121 of the SEPP.</p> <p>The proposed development on the site is not a traffic generating development for the purposes of this SEPP.</p>

The following SEPPs are not applicable to this planning proposal:

- SEPP (Precincts – Central River City) 2021, SEPP (Precincts – Regional) 2021, SEPP (Precincts – Western Parkland City) 2021, SEPP (Primary Production) 2021

Is the planning proposal consistent with applicable Ministerial Directions (section 9.1 Directions) or key government priority?

The following table (Table 2) outlines the consistency of this planning proposal with applicable Ministerial Directions

Table 2. Consistency with Ministerial Directions

Ministerial Direction	Comment
1.1 Implementation of Regional Plan	This planning proposal is consistent, as demonstrated in section 5.3 of this document.

Ministerial Direction	Comment
1.3 Approval and Referral Requirements	This planning proposal is consistent. No provisions are being proposed that would require the concurrence, consultation or referral of development applications to a Minister or public authority, nor identify the development as designated development.
1.4 Site Specific Provisions	This planning proposal is consistent. The planning proposal provides development uplift to support commercial development. The planning proposal does not unnecessarily restrict the permitted uses on the land. Development that does not make use of the uplift provided by the planning proposal can continue to make use of the full range of uses permitted in the MU1 zone.
3.1 Conservation Zones	This planning proposal is consistent. The site is not located within an environmentally sensitive area, a conservation zone nor land otherwise identified for environment conservation/protection purposes.
3.2 Heritage Conservation	This planning proposal is consistent. There are no heritage-listed items on the site, and the site's location within the Woolloomooloo Heritage Conservation Area (C71) and proximity to heritage items are considered by the planning proposal. The City has undertaken a review of conservation area boundaries, and as part of this review it is proposed to adjust the Woolloomooloo Heritage Conservation Area's boundaries to remove the site and some other nearby sites from the conservation area. Heritage reports, provided by the proponent, are at Attachments A6, A7 and A8.
3.5 Recreation Vehicle Areas	This planning proposal is consistent. The site is not being developed for the purpose of a recreation vehicle area.
3.7 Public Bushland	This planning proposal is consistent. The site does not contain any urban bushland.
3.9 Sydney Harbour Foreshores and Waterways Area	This planning proposal is consistent. The site is not located within the Foreshore and Waterways Area.
3.10 Water Catchment Protection	<p>This planning proposal is consistent. The site is located within the Sydney Harbour Catchment but outside the Foreshore and Waterways Area Boundary. The planning proposal does not conflict with the objectives of the Direction.</p> <p>The existing building has full site coverage, and the proposed building envelope also allows full site coverage. Given this, any future development is unlikely to impact water flows within the catchment.</p>
4.1 Flooding	This planning proposal is consistent. The proponent has identified that the site is on flood affected land and has

Ministerial Direction	Comment
	<p>provided a Flood Impact Assessment (See Attachment A9). This assessment makes recommendations for the proposed development to reduce risks and effects associated with flood behaviour.</p> <p>Detailed Flood Impact and Risk Assessment (FIRA) and Flood Emergency Response Plan (FERP) reports would need to be submitted to Council in relation to future development applications relating to this site.</p>
4.2 Coastal Management	<p>This planning proposal is consistent. The site is not located within the coastal environment area or coastal use area.</p>
4.4 Remediation of Contaminated Land	<p>This planning proposal is consistent.</p> <p>The existing building on the site dates from the mid-1960s. It was constructed as an office building and this use continues today.</p> <p>Historical records show the site was used as a coach building and motor car workshop in the early 1900s.</p> <p>The City has considered the potential for contamination reflecting the history of the site. Further investigation regarding potential contamination and remediation will be undertaken as part of any future development application process.</p>
4.5 Acid Sulfate Soils	<p>The planning proposal is consistent.</p> <p>The site is located on Class 2 acid sulfate soil land under section 7.14 of the Sydney LEP 2012.</p> <p>The existing building on the site has a basement level. The planning proposal incorporates a basement level and this is below the natural ground surface. An acid sulfate soils management plan would need to be submitted to Council as part of any future development application for the site.</p>
5.1 Integration Land Use and Transport	<p>This planning proposal is consistent. The site is located in an area that is well serviced by existing public and private transport options.</p>
5.3 Development near Regulated Airports and Defence Airfields	<p>This planning proposal is consistent.</p>
6.1 Residential Zones	<p>This planning proposal is consistent. The planning proposal does not prevent a residential use from occurring on the site under the current zoning and development standards. It introduces additional standards to encourage commercial uses.</p>
6.2 Caravan Parks and Manufactured Home Estates	<p>This planning proposal is consistent. It provides an alternative set of planning controls for the commercial</p>

Ministerial Direction	Comment
7.1 Employment Zones	<p>redevelopment of the site. It is not a suitable zone or location for the provision of a caravan park.</p> <p>This planning proposal is consistent. It will encourage employment growth in a suitable location, as well as protect and support the viability of an area identified in the relevant regional and district plans and LSPS for commercial uses.</p>

The following Ministerial Directions are not applicable to this planning proposal:

- Ministerial Direction 1.2 Development of Aboriginal Land Council Land, 1.4A Exclusion of Development Standards from Variation, 1.5 Parramatta Road Urban Transformation Strategy, 1.6 Implementation of North West Priority Growth Area Land Use and Infrastructure Implementation Plan, 1.7 Implementation of Greater Parramatta Priority Growth Area Interim Land Use and Infrastructure Implementation Plan, 1.8 Implementation of Wilton Priority Growth Area Interim Land Use and Infrastructure Implementation Plan, 1.9 Implementation of Glenfield to Macarthur Urban Renewal Corridor, 1.10 Implementation of the Western Sydney Aerotropolis Plan, 1.11 Implementation of Bayside West Precincts 2036 Plan, 1.12, Implementation of Planning Principles for Cooks Cove Precinct, 1.13 Implementation of St Leonards and Crows Nest 2036 Plan, 1.14 Implementation of Greater Macarthur 2040, 1.15 Implementation of the Pymont Peninsula Place Strategy, 1.16 North West Rail Link Corridor Strategy, 1.17 Implementation of the Bays West Place Strategy, 1.18 Implementation of the Macquarie Park Innovation Precinct, 1.19 Implementation of the Westmead Place Strategy, 1.20 Implementation of the Camellia-Rosehill Place Strategy, 1.21 Implementation of the South West Growth Area Structure Plan, 1.22 Implementation of the Cherrybrook Station Place Strategy, 3.1 Conservation Zones, 3.3 Sydney Drinking Water Catchments, 3.4 Application of C2 and C3 Zones and Environmental Overlays in Far North Coast LEPs, 3.6 Strategic Conservation Planning, 3.8 Willandra Lakes Region, 4.3 Planning for Bushfire Protection, 4.6 Mine Subsidence and Unstable Land, 5.2 Reserving Land for Public Purpose, 5.4 Shooting Ranges, 7.2 Reduction in non-hosted short-term accommodation period, 7.3 Commercial and Retail Development along the Pacific Highway, North Coast, 8.1 Mining, Petroleum Production and Extractive Industries, 9.1 Rural Zones, 9.2 Rural Lands, 9.3 Oyster Aquaculture, 9.4 Farmland of State Regional Significance on the NSW Far North Coast.

5.4 Environmental, social and economic impact

Is there any likelihood that critical habitat or threatened species, populations or ecological communities, or their habitats, will be adversely affected because of the proposal?

The planning proposal applies to a site in Woolloomooloo which is occupied by a part two/part three storey commercial office building without any existing vegetation within its boundaries. Any redevelopment would be an intensification of commercial uses and similar to surrounding buildings. It is highly unlikely for any adverse impact on a critical habitat or threatened species, population or ecological community as a result of this proposal.

Are there any other likely environmental effects of the planning proposal and how are they proposed to be managed?

Floor Space Ratio

This planning proposal will insert a site-specific floor space ratio (FSR) control into Sydney LEP 2012, which will be available to support the commercial redevelopment of the site.

The planning proposal establishes a maximum FSR of 3.8:1 to support commercial uses, excluding any bonus FSR available at basement level for end of journey facilities. This FSR control is specific to the building envelope outlined in this planning proposal.

The indicative design demonstrates how the desired density is consistent with the surrounding area and will result in additional commercial floor space without significant adverse impacts. It also indicates that it will be possible to accommodate the proposed FSR within the dimensions of the proposed building envelope while applying standard assumptions for space efficiencies and floor-to-floor heights.

Given the site's proximity to Central Sydney and its location in the City Fringe, the planning proposal is an appropriate response to encourage redevelopment of the site for employment generating uses.

Building height and envelope

The planning proposal will insert a site-specific building height control in Sydney LEP 2012, which will be available to support the commercial redevelopment of the site. The increase in the maximum building height from 12 metres to 25 metres would facilitate the increase in FSR. Site-specific DCP controls will establish a maximum building envelope, demonstrating the maximum permitted height, along with maximum street wall heights and setbacks.

The proposed height of 25 metres is considered reasonable in the context of the site's surrounds. The height is compatible with the diversity of building heights in the vicinity, including low and mid rise buildings in the immediate street block and the high rise developments to the east, west and south of the site.

The proposed building envelope has been designed to respond to the built form of Riley Street and Busby Lane. At ground level, the building envelope adopts a zero setback from all site boundaries, which is consistent with other development in this highly urbanised area. The proposed building envelope includes a three storey podium, with two storeys above with a 3 metre setback on the Riley Street frontage and a 0.57 metre setback on the Busby Lane frontage. Provision has also been made at roof level for lift overruns, roof access and amenities alongside a pergola structure.

A street wall height of three storeys is proposed along both the Riley Street and Busby Lane frontages. This enables a transition from a two storey street wall immediately to the south and a four storey street wall immediately to the north.

The proposed envelope will allow a future building to respond to the context of the site. The proposal respects the scale of immediately adjoining properties through a podium, and with zero setbacks the building's edge will contribute to a cohesive streetscape form.

Figure 19. Proposed maximum building envelope – 3D view from the north east

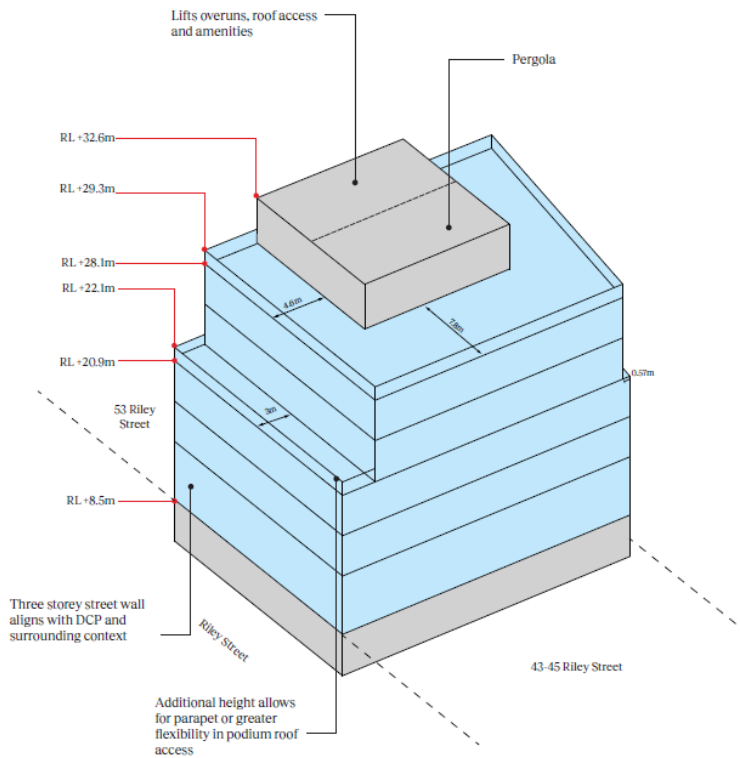

Figure 20. Proposed maximum building envelope – 3D view from the south west

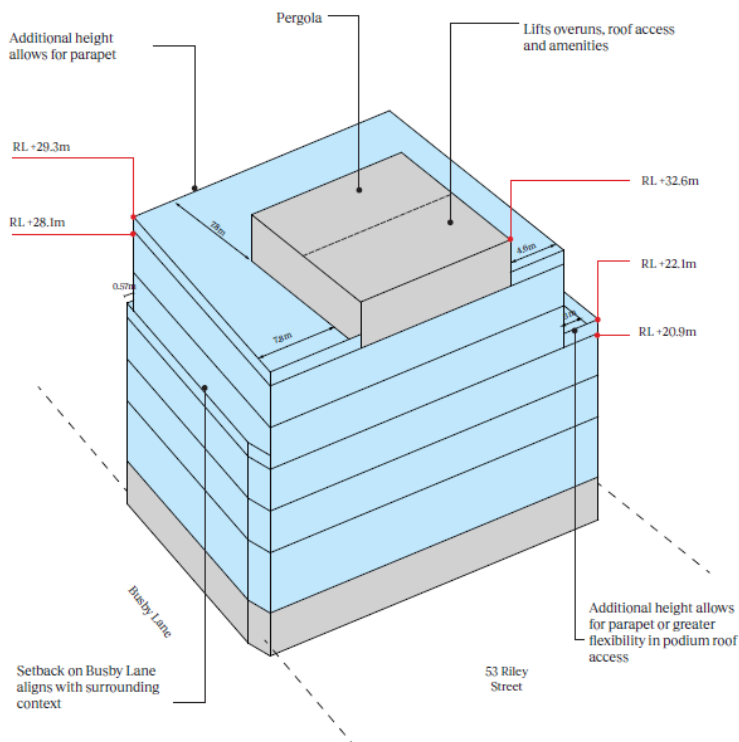

Figure 21. Proposed maximum building envelope – Riley Street elevation

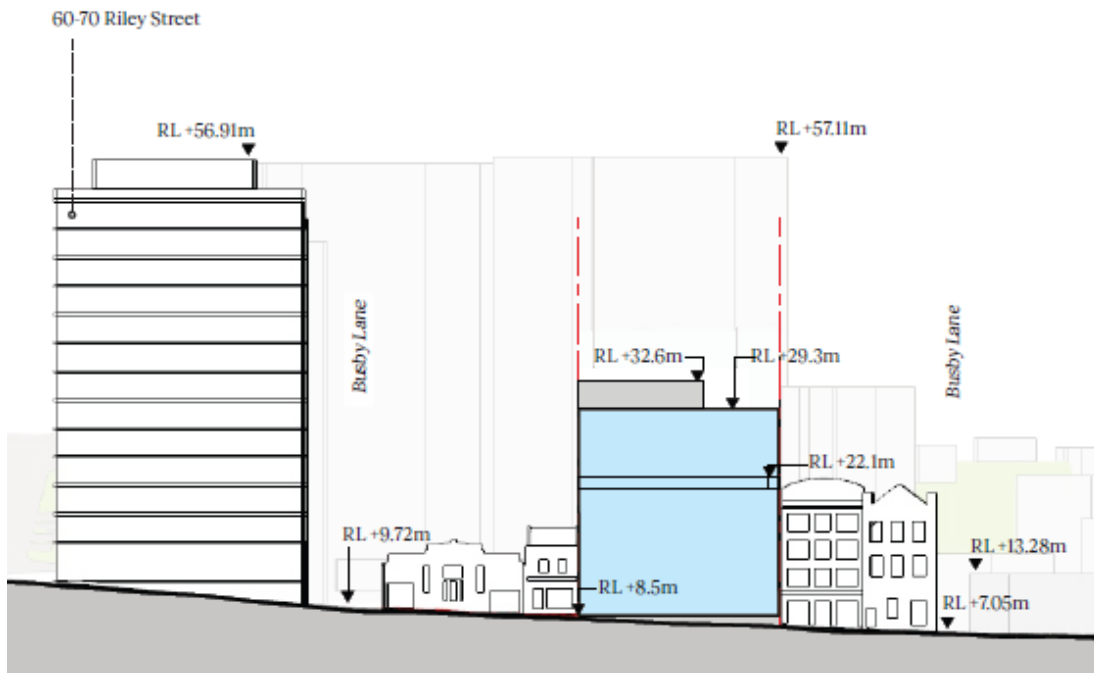
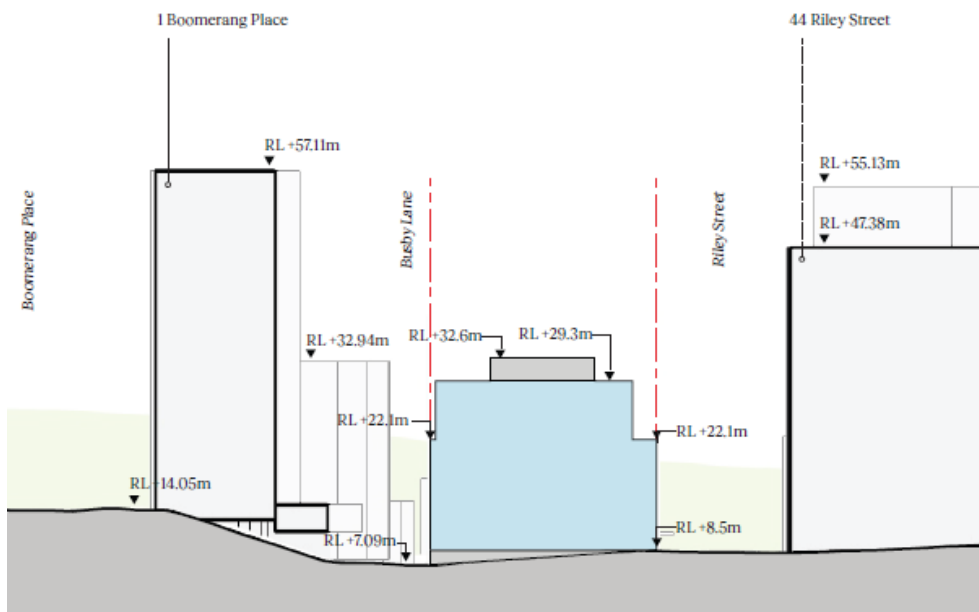

Figure 22. Proposed maximum building envelope – looking north



Overshadowing

The proponent has prepared shadow diagrams to show the potential overshadowing impact of the development on nearby properties, the results of which can be found in the Urban Design Report at Attachment A4 of this planning proposal.

The building at 60-70 William Street which is a mixed use development with residential apartments located to the south of the site, required further investigation. Façade testing of the northern elevation of this building showed that only 0.5% of the residential façade would experience additional overshadowing impacts, but that all apartments would continue to achieve two hours of solar access in mid-winter. Figure 23 shows the existing and proposed solar impacts of the development on the residential façade of 60-70 William Street.

Figure 23. Existing and proposed shadow impacts on residential façade of 60-70 William Street to the south

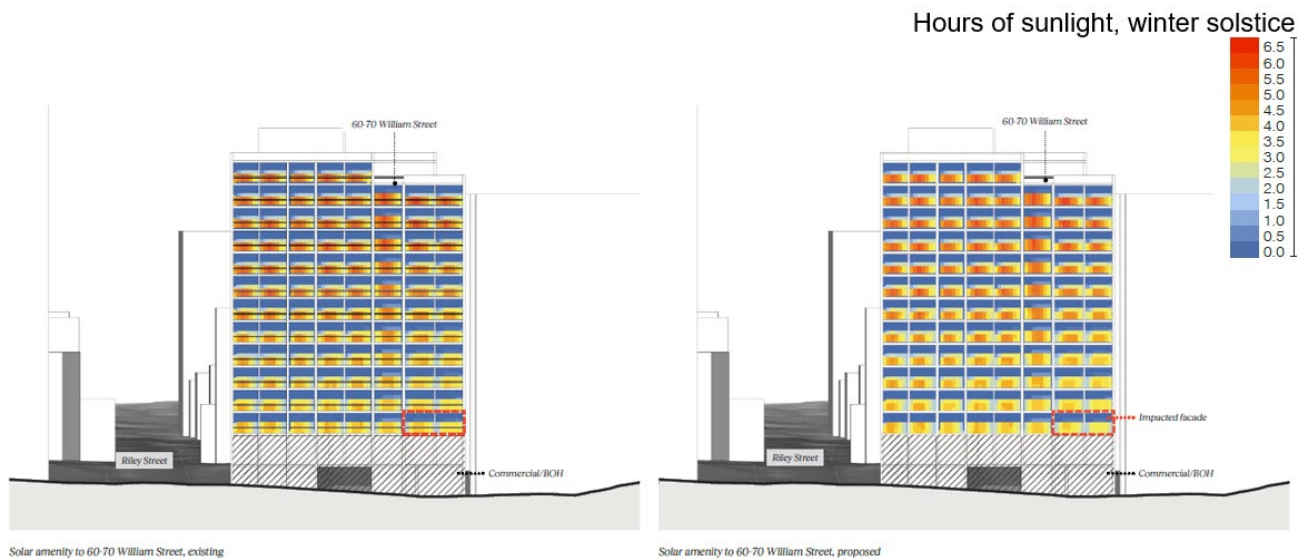

Views and visual impact

The proposed building envelope's impact on the views available from nearby properties has been considered. As demonstrated in Figure 24, from high rise buildings near the site there would be key local views towards St Marys Cathedral, the CBD skyline, the Domain, the Sydney Harbour Bridge, Woolloomooloo Bay and the Finger Wharf. A view impact assessment undertaken by the proponent indicates that from nearby buildings (46-47 Riley Street and 60-70 William Street), the proposed building envelope sits within the surrounding built form and does not impact on key local views out from these properties. This view impact assessment is within the Urban Design Report at Attachment A4 of this planning proposal.

The proponent's view impact assessment is limited to the consideration of views from two apartments. It may be that there are some impacts on views and outlook from apartments on the lower levels of these nearby buildings, but it is likely that the majority of apartments in these buildings will not have views or outlook adversely impacted.

Figure 24. Key local views from nearby buildings

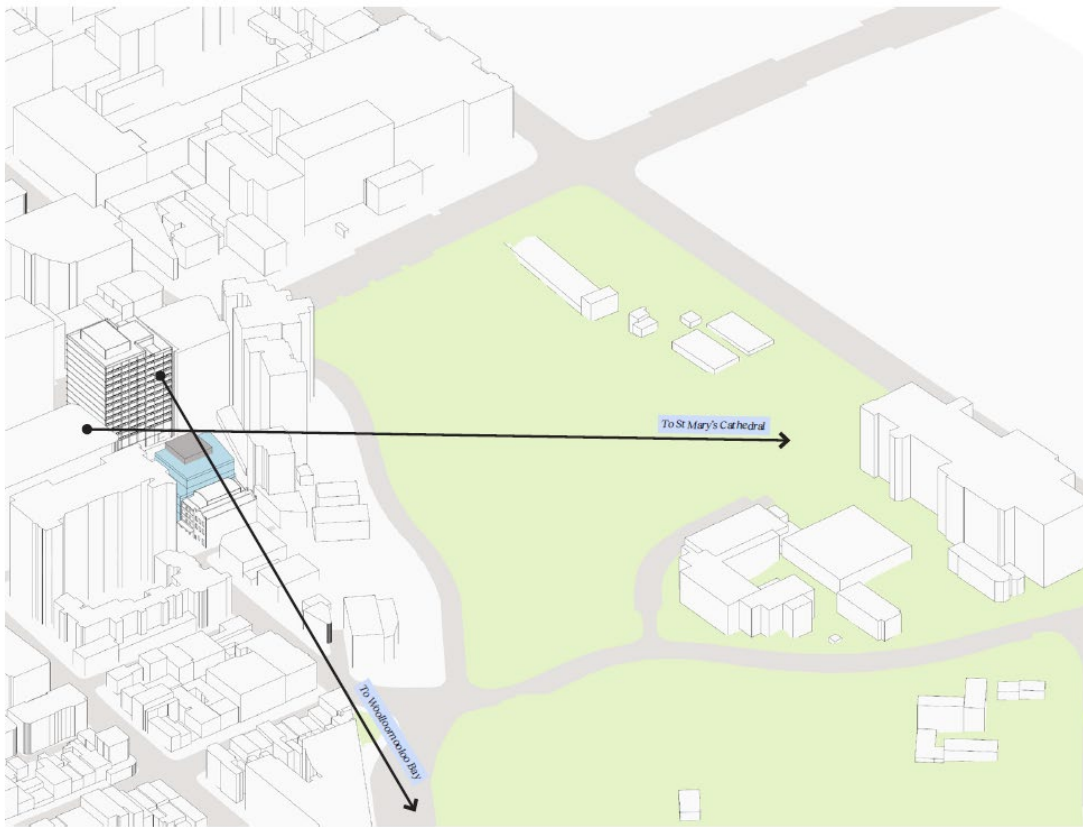

The visual impact of the proposed building envelope on streetscapes and from the Domain nearby has also been considered. The proposed building envelope, with its three storey street wall height and upper level setbacks, responds to the built form of adjacent buildings, and provides a transition from the two storey buildings to the immediate south of the site to the three and four storey buildings to the immediate north. Views from the Domain indicate that the proposed building envelope sits within surrounding buildings, which results in minimal visual impact when viewed from the park. The visual impact assessment is within the Urban Design report at Attachment A4 of this planning proposal.

Ground floor activation

The planning proposal includes retail floor space at ground floor level fronting Riley Street, to contribute to the activation of the street front. The indicative reference scheme submitted as part of the planning proposal documentation shows a lobby for the building's commercial suites being accessed from the Riley Street frontage of the building. See Figure 25.

The site specific DCP (Attachment B) will contain provisions requiring a minimum of 158 square metres of retail floor space at ground floor level, with a minimum frontage to Riley Street of 11.5 metres. It will also require main pedestrian access to be from Riley Street and the commercial lobby to be visible from Riley Street. Combined, the retail use and commercial lobby for the building will make a positive contribution to the activation and vibrancy of Riley Street.

Figure 25. Ground floor plan of indicative design showing retail use and commercial lobby fronting Riley Street



Transport and servicing

A transport report, prepared by Colston Budd Rogers and Kafes Pty Ltd, was submitted with the planning proposal documentation and is at Attachment A10 to this planning proposal. This report notes that the site has excellent access to public transport services, and that the proposed development will increase employment densities close to existing public transport services.

The indicative design submitted with the planning proposal proposes a basement carpark accessed from Busby Lane, but with the vehicular access point on the southern side of the Busby Lane frontage (rather than on the northern side as it is for the existing development on the site). The indicative design depicts a basement level accessed via a ramp with seven parking spaces (inclusive of one visitor space), a loading zone, a bike store for 24 bikes, end of journey facilities, a bin holding area and a fire pump room. See Figure 26.

Based on the floor space type and quantity proposed in the indicative design, the maximum number of car parking spaces under Sydney LEP 2012 that would be permitted on site would be 14 (11 for the commercial floor space and 3 for the retail floor space). While the final on-site parking provision will be determined at the development application stage, the indicative design includes only seven parking spaces, which is in accordance with the maximum number of parking spaces that may be provided as per section 7.6 of the Sydney LEP 2012.

The indicative scheme includes bicycle parking for 24 bikes, which is in accordance with section 3.11.3 of the Sydney DCP 2012 which requires 22 bike parking spaces based on the commercial and retail floor space. End of journey facilities are also proposed in the basement, relying on the end of journey floor space provisions at Section 6.13 of the Sydney LEP 2012.

The transport report indicates that the development would have very low traffic generation, equivalent to an average of less than one vehicle every 12 minutes, and as such would not have noticeable effects on the operation of the surrounding road network.

With regard to waste servicing, the indicative design shows a bin holding area at ground floor level at the rear of the building, which can be accessed from Busby Lane. This would enable on-street collection with bins being rolled in/out of the site (rather than sitting on the street for collection). While this is a potential option, it is recommended that as part of the future detailed design of a scheme for the site the proponent further explore options for accommodating waste collection on site.

With regard to vehicular entry and exit from the site, it appears that B99 vehicles appear not to be able to achieve clear entry and exit swept paths. Swept paths within the basement itself will also need to demonstrate how vehicles get into and out of the loading bay.

More detailed assessments will be needed as part of any future development application for the site, to ensure orderly waste servicing as well as safe vehicular movement into and out of the site and around the basement.

Figure 26. Indicative design of basement carpark

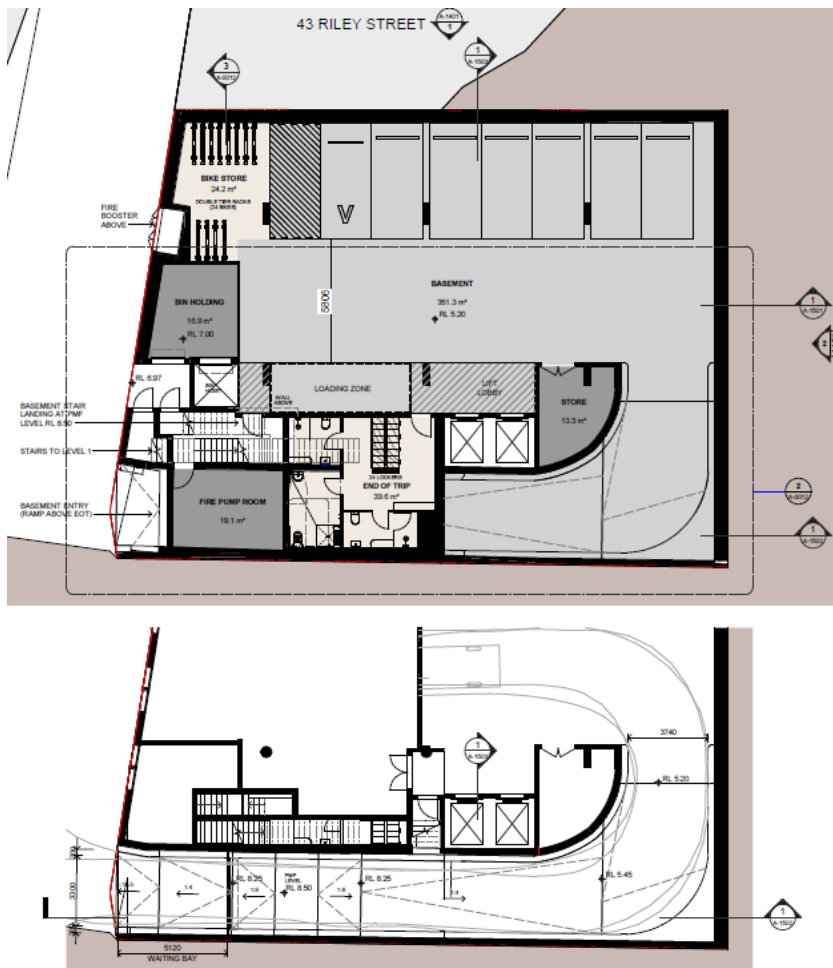

Basement Ramp - Plan
51 Riley Street

Flooding

The site is identified as flood affected in major and minor flood events as per the City's Woolloomooloo Catchment Flood Study & Floodplain Risk Management Study and Plan 2016. The flood study shows a major overland flow path along Riley Street during flooding events, but that the peak depth of flooding in Riley Street would be shallow, compared to depths in Busby Lane. The mapping shows the low point at the northwest corner of Busby Lane as being flood affected.

A Flood Impact Assessment prepared by Barker Ryan Stewart Pty Ltd and submitted in support of the planning proposal (see Attachment A9) notes that flood behaviour in Busby Lane is largely controlled by the trapped low point at its northern end, causing floor waters to pond until spilling back onto Riley Street downstream of the site.

The City advised the proponent that the proposed floor levels for the retail and front lobby are in the indicative design were too low at RL 8.5m, and below the 10% Annual Exceedence Probability (AEP) for a flood event of RL8.85m and the 1% AEP for a flood event of 8.9m. The key concern at planning proposal stage was that addressing this may affect floor levels and therefore the overall height of the building envelope.

The proponent responded to this concern by raising the floor levels of the retail and front lobby area by 50mm, to a height of RL8.55m. The applicant advised that any future modification to lobby/retail levels would have no impact on the overall building height.

Following this amendment, the City's stormwater engineer has advised that the planning proposal is acceptable, but detailed Flood Impact and Risk Assessment (FIRA) and Flood Emergency Response Plan (FERP) reports are to be submitted in relation to future development applications relating to this site.

Sustainability

Any future development application for a commercial use which relies on the controls made by this planning proposal will be subject to the sustainability requirements within:

- State Environmental Planning Policy (Sustainable Buildings) 2022 (Sustainable Buildings SEPP);
- Section 7.33 of the Sydney LEP 2012; and
- Section 3.6.1 "Energy efficiency in non-residential developments" of the Sydney DCP 2012.

A detailed sustainability strategy would need to be submitted with any future development application demonstrating compliance with these requirements.

Green roof

The proponent's request for a planning proposal shows that at roof level, provision has been made for lift overruns, roof access and amenities alongside a pergola structure. The indicative design shows a communal area and 79 square metres of planting at roof level.

The draft DCP for the site includes a requirement for a green roof of a minimum of 148 square metres, which is a higher requirement than what has been shown in the indicative scheme. This higher requirement is consistent with the green roof replacement rates currently proposed by the in the LEP/DCP Update Draft DCP, and recognises that deep soil tree planting cannot be achieved given that full site coverage is anticipated. A future development application for the site would need to include a green roof which complies with the City's green roof provisions.

Has the planning proposal adequately addressed any social and economic effects?

Economic impact

This planning proposal provides an opportunity for the redevelopment of the subject site to provide additional commercial and retail floor space in the metropolitan centre of the Eastern City District (Harbour CBD). This is in alignment with the objectives of the Greater Sydney District Plan and the Eastern City District Plan which seek to encourage investment and business activity and support growth in areas well serviced by existing infrastructure and transport connections.

The planning proposal will facilitate approximately 2,150 square metres of employment generating floor space, which equates to around 90 jobs. These jobs will be on a site well positioned to take advantage of existing transport and social infrastructure.

Heritage

Three heritage reports have been submitted in support of the planning proposal:

- 1) Aboriginal Heritage Due Diligence assessment prepared by Extent Heritage (See Attachment A6)

This due diligence assessment identified no Aboriginal Objects or Places present within the site. It noted that while there have been Aboriginal stone artefacts recovered from excavations less than 50m from the site, the process of constructing the basement of the existing building is likely to have removed any remaining soils that might have had potential to include Aboriginal objects. Due to this prior disturbance, there is not a likelihood of Aboriginal objects being present on the site.

- 2) a Baseline Historical Archaeological Assessment prepared by Extent Heritage (See Attachment A7)

This assessment concluded that the site has nil-to low potential for archaeological remains associated with Phase 1 (1793-1843) or Phase 2 (1844-1901) of historical development of the site. It noted that the high level of disturbance during Phase 3 (1902-present) of historical development of the site has reduced the potential for historical deposits from previous phases from nil-to low. These disturbances included the construction of a pre-1943 building on the site and the construction of the basement of the current building on the site in 1966.

The assessment of the proposed redevelopment of the site indicates that historical deposits are unlikely to be encountered during the construction of the new building and its basement.

- 3) a Heritage Impact Statement prepared by NBRS & Partners Pty Ltd (See Attachment A8)

The site is not listed as an item of local heritage significance in the Sydney LEP 2012. It is however located in close proximity to a number of local heritage items and is within the Woolloomooloo Heritage Conservation Area (C71) under the Sydney LEP 2012. The existing building on the site is categorised as a “detracting” building within the Woolloomooloo Conservation Area in Sydney DCP 2012.

This report notes that the City has undertaken a review of the boundaries of the conservation areas, and it is proposed to remove the site and other sites from the Woolloomooloo Conservation Area (refer to Figure 14 of this Planning Proposal). While this proposal is still at pre-exhibition stage, it recognises that the site and surrounds do not contribute to conserving the character, scale or significance of the Woolloomooloo Conservation Area.

The report concludes that the planning proposal to adjust the height and FSR controls for the site will result in an acceptable impact on the heritage significance of the Woolloomooloo Conservation Area and heritage items in the vicinity. It states that the proposal aligns with the intention to refine the Woolloomooloo Conservation Area boundaries, and existing views to and from heritage items in the vicinity of the site will be retained.

The report also concludes that the proposed building envelope retains the scale and form of the existing streetscape by establishing a podium at the lower levels with a street edge in line with adjacent buildings. The upper levels are setback and are viewed in the context of nearby high rise buildings.

Given the conclusions of these heritage studies and the City’s proposal to remove the site from the Woolloomooloo Conservation Area, it is considered that the planning proposal is acceptable in terms of heritage impacts. Any future development application for the site would need to address heritage impact, with consideration of detailed building form, articulation and materiality.

5.5 Infrastructure (Local, State and Commonwealth)

Is there adequate public infrastructure for the planning proposal?

The site is located within walking distance of the Sydney CBD, with numerous rail, light rail and bus services in close proximity. The site is in close proximity to public spaces such as Cook and Phillip Park, Hyde Park and the Domain. The site is already serviced by public utilities including water, sewer and stormwater, electricity and telecommunications. There is adequate public infrastructure to support this planning proposal.

Any development application for the site will be subject to section 7.11 development contributions under the City of Sydney Development Contributions Plan 2015, to ensure that the additional demand for infrastructure generated by the proposal can be met through the provision of new or improved infrastructure.

5.6 State and Commonwealth interests

What are the views of the state and federal public authorities and government agencies consulted in order to inform the Gateway determination?

The gateway determination will advise the public authorities to be consulted as part of this planning proposal process. Any issues raised will be incorporated into this planning proposal following consultation in the public exhibition period.

6. Mapping

The planning proposal does not include any amendments to maps.

No change will be made to maps in the Sydney LEP 2012 as part of this planning proposal. Instead, new site specific provisions relating to height and FSR will be inserted into Part 6, Division 5 of Sydney LEP 2012. A draft version of example clauses that may be inserted is at Appendix 1 of this planning proposal.

It is also noted that no change will be made to maps in the Sydney DCP 2012. Rather, new site specific provisions relating to built form, site access and servicing, street activation and urban ecology will be inserted into Section 6 of Sydney DCP 2012.

7. Community consultation

This Planning Proposal is to be exhibited in accordance with a Gateway Determination issued by the Department of Planning, Housing & Infrastructure.

It is anticipated that the Gateway Determination will require public exhibition for a period of not less than 28 days in accordance with the Environmental Planning and Assessment Act 1979 and the Local Environmental Plan Making Guideline.

Notification of the public exhibition will be consistent with the Gateway Determination and the City's Community Engagement Strategy and Participation Plan.

Consultation with relevant NSW agencies, authorities and other relevant organisations will be undertaken in accordance with the Gateway Determination.

8. Project timeline

The anticipated timeframe for the completion of the planning proposal is as follows:

Stage	Timeframe
Commencement / Gateway Determination	September 2024
Government agency consultation	October – November 2024
Public exhibition	November – December 2024
Consideration of submissions	December 2024 – January 2025
Post exhibition consideration of proposal	February 2025
Draft and finalise LEP	March – April 2025
LEP made	April – May 2025
Plan forwarded to the Department of Planning, Housing & Infrastructure	June 2025

Appendix 1

Example clauses

The final version of the clauses to be inserted into Part 6, Division 5 of the Sydney LEP 2012 would be subject to drafting and agreement by the Parliamentary Counsel's Office, but may be written as follows:

Part 6 Local provisions – height and floor space

Division 5 Site specific provisions

6.XX 47 – 51 Riley Street, Woolloomooloo

- (1) This clause applies to 47- 51 Riley Street, Woolloomooloo, being Lot 1, DP 83489.
- (2) Despite clauses 4.3 and 4.4, the consent authority may grant development consent for a building on the land to which this clause applies that will result in a building –
 - (a) with a maximum building height of 25 metres,
 - (b) with a maximum floor space ratio of 3.8:1, and
 - (c) which will only be used as a commercial premises.
- (3) Development consent must not be granted under this clause unless the consent authority is satisfied that the resulting building will not be used for the purposes of residential accommodation or serviced apartments.
- (4) This clause does not limit the operation of clause 6.13 in its application to the land which this clause applies.

